

Ref. : CC 3241.pas

Rev. : G

Date : 27/01/2015

Page : 1/1

# FLANGED TYPE FOOT CHECK VALVE

## CC 3241



**Tecofi'**  
VALVE DESIGNER - FRANCE

### APPLICATION

General uses : pumping, hydrocarbon, industry, clean water.  
Vertical mounting required

### GENERAL CHARACTERISTICS

From DN 50 to DN 150.  
From DN 200 to DN300 on request.  
Excellent tightness.  
Low head loss.  
Extremely reliable.  
Excellent hydraulic result.  
Simplicity in mounting and use.

### CONSTRUCTION

7	1	Strainer	Galvanized steel	
6	1	Seat	NBR	
5	1	Spring	Stainless steel	
4	1	Guiding stem	CuZn40Pb2	
3	1	Disc	Ductile iron EN-GJS-400-15	DIN: GGG40 ASTM: A536 65-45-12 BS: 1563 EN-JS1030
2	1	Guide	Ductile iron EN-GJS-400-15	DIN: GGG40 ASTM: A536 65-45-12 BS: 1563 EN-JS1030
1	1	Body	Cast iron EN-GJL-250	DIN: GG25 ASTM: A48 class 40B BS: 1452 Grade 250
<b>Pos.</b>	<b>Qty.</b>	<b>Description</b>	<b>Material</b>	

### DIMENSIONS

DN (mm)	50	65	80	100	125	150	200	250	300
L	100	120	140	170	200	230	300	370	410
A	80	100	120	150	175	200	250	300	350
Ø D	165	185	200	220	250	285	340	405	460
Ø B	111	131	148	168	198	222	278	329	384
Ø K	125	145	160	180	210	240	295	350	400
n x Ø d0	4 x 18	4 x 18	8 x 18	8 x 18	8 x 18	8 x 22	12 x 22	12 x 22	12 x 28
Weight (kg)	5,72	8,64	10,47	14,4	22,1	31,6	50,1	72	117

### WORKING CONDITIONS

Maximum working pressure : 16 bar.  
Maximum temperature : + 100°C.

Pressure test according to standards  
EN 12266-1, DIN 3230, BS 6755 and ISO 5208 :  
Body : 24 bar.  
Seat : 17,6 bar.

### STANDARDS

Flanged ISO PN 16, DIN 2501/1, UNI 2223/67 and  
ASA 150 on request.

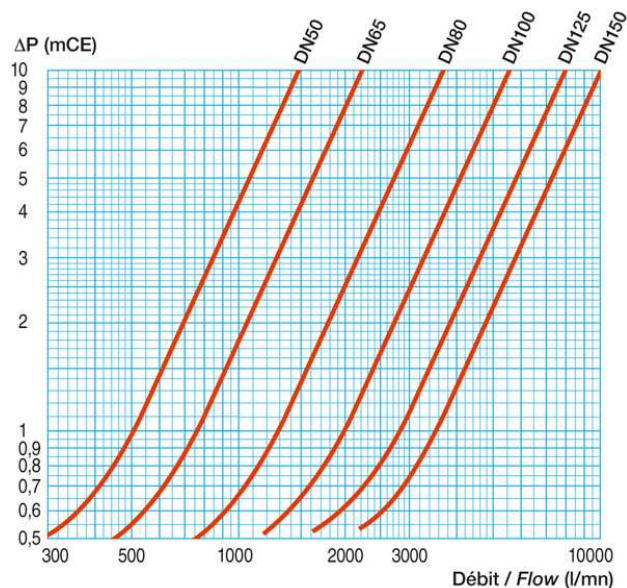
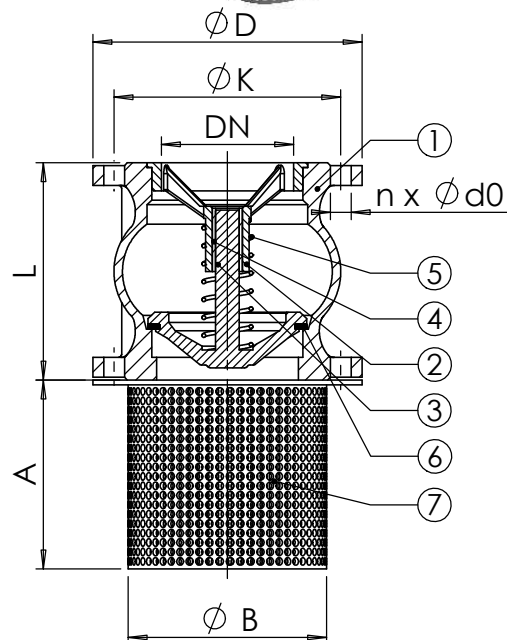

mCE : mètre colonne d'eau / meter water column

**TECOFI France** - 83, Rue Marcel Mérieux 69960 Corbas - FRANCE  
Tél. +33 (0) 4 72 79 05 79 - Fax +33 (0) 4 78 90 19 19 / +33 (0) 4 72 79 05 70  
Adresses e-mail : sales@tecofi.fr ; tecofi@tecofi.fr / Site web : [www.tecofi.fr](http://www.tecofi.fr)